

Patented Orbits Transfers and Manoeuvres Review

ISSFD-2017-179 /ISTS--2017-d-179

Presented at Joint Conference of 31st International Symposium on Space Technology and Science
26th International Symposium on Space Flight Dynamics and 8th Nano-satellite Symposium,
Matsuyama, Japan
June 3 – 9, 2017

By Christophe Koppel¹⁾

¹⁾KopooS Consulting Ind., 57 rue d'Amsterdam, 75008 Paris, France

(Received April 17th, 2017)

The paper will review a large non-exhaustive list of patents dealing with flight dynamics orbital transfers. Curiously among the scientific communities working on the orbit transfer, the question of using already patented orbit transfer or not is almost never pointed out. Some famous patents are "a priori" however restricting the possible answers to a given orbital mechanic problem. The Arnon Spitzer patent⁶⁾ about the inertial direction of the low thrust during an orbit transfer between Super-GTO and GEO, or the Koppel patent⁷⁾ are typical examples of the patents found in the Intellectual Property (IP) databases. The paper will open the discussion about the real patentability of such trajectories and manoeuvres, but the paper will not give any conclusion on those aspects. However, recommendations for the community will be proposed.

Key Words: Patent, orbit transfer, discussion, recommendation

Nomenclature

EP : electric propulsion
GEO : geostationary Earth orbit
S/C : spacecraft

1. Introduction

According to the Registration Convention^{1) 3)}, every space object is required to be registered in (at least one of) the launching state(s).

The Outer Space Treaty^{2) 3)} requires that the state of registration "*shall retain jurisdiction and control over such object, and over any personnel thereof, while in outer space or on a celestial body.*"

According to Kleiman^{4) 3)} this means that such treaty permits or allows countries to extend their laws and patent laws, to their registered space objects. This may induce that "*any invention made, used, or sold in outer space on a space object or component thereof under the jurisdiction or control of [... a country] shall be considered to be made, used or sold within [... that country]*"⁴⁾, as has been enacted for example within the United States.

Hence, for countries that have elected to extend patent laws to registered S/C, an invention created on a country-registered spacecraft (S/C) would be deemed to have been invented in the country and a patent infringement lawsuit based on an activity on a S/C registered in the country must be brought in a court of that country and would only succeed if the activity is covered by a patent in the country⁴⁾.

This shows that in this context, patents dealing with new flight dynamics orbit transfers (and granted in the state of registration of the S/C) are in force and their infringement or

counterfeits can be brought to justice in the state of registration of the S/C.

So after this short introduction recalling the force of any patent, the paper will review a large non-exhaustive list of patents dealing with orbital transfers. Curiously among the scientific communities working in flight dynamics on the orbit transfer, the question of using already patented orbit transfer or not is almost never pointed out. However, certain patents "a priori" restrict the ability of S/C registered within the jurisdiction where those patents are in effect to implement or execute certain orbital manoeuvres following specific orbital trajectory evolutions without implicating infringement of those patents. This point will be developed in the next chapter.

In a further chapter, the paper will open the discussion about the real patentability of such trajectories and manoeuvres, but the paper does not give any conclusion on those aspects. Eventually, recommendations for the community will be proposed.

2. Patents on Orbit transfer

The introduction of the Electric Propulsion (EP) aboard S/C since mid-90 has resulted in several patents relevant to orbit transfer because the field of "low-thrust orbit transfer" had been previously only analysed on theoretical point of view without any patents. One can cite for example the famous work of Edelbaum⁵⁾ on optimum low-thrust orbit transfer between circular orbits producing an analytic formula (the so-called Edelbaum's formula) that was found a long time before the EP transfer realm was seriously considered. But when the power aboard S/C became large enough to enable this kind of high performance propulsion, still with low-thrust but much higher than before, new operational

strategies were discovered and patented.

Two different patents on Orbit transfer with EP are to be highlighted first.

2.1 Spitzer patent⁶⁾

It is remarkable that in 1994, a patent was demanded for an orbit transfer using in its last part a continuous thrust for following a spiralling trajectory: this is the Spitzer Patent.

The main claim of this patent can be summarised (for flight dynamics experts) as essentially requiring the following:

"... firing the propulsion thruster at apogees of intermediate orbits to successively increase the perigees

thereof until the semi-major axis of an intermediate orbit is substantially equal to the semi-major axis of the geosynchronous orbit to define an initial transfer orbit thereafter continuously firing the propulsion thruster to translate the orbit of the spacecraft from the initial transfer orbit to said geosynchronous orbit"

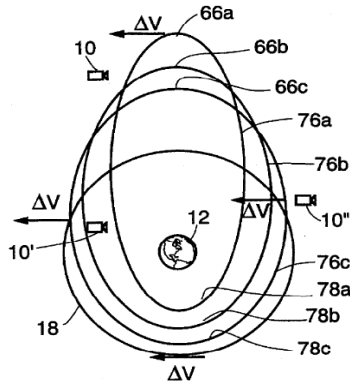

Figure 1: Continuous thrust during the translation part⁶⁾

The last part of this main claim, so called "translation", is the most interesting for flight dynamic (even if to get infringement, it cannot be taken alone) which is to turn on a continuous thrust from a starting elliptic orbit having a 24 h period (i.e. same semi-major axis of GEO) up to circular GEO.

and in further dependant claims, the orientation of the thrust is claimed to be constant.

and it is even perpendicular to the apogee during the translation part as shown on the drawing by the ΔV vectors in Figure 1

2.2 Koppel patent⁷⁾

Two years later, in 1996 the Koppel patent was demanded. Its main claim can be summarised as essentially requiring:

...a control device for putting the thrusters into continuous operation... via a completely spiral trajectory, ignoring possible service interruptions,... a thrust direction control..., first means ...during a first stage of continuous ... on each successive revolution ... apogee altitude increases, perigee altitude increases to a lesser extent, ...

and ... second means ...during a second stage ... on each successive revolution ...apogee altitude decreases, perigee altitude increases....

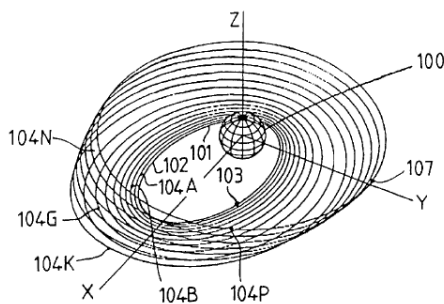

Figure 2: Continuous thrust during the whole orbit transfer⁷⁾

The whole strategy disclosed can be first quite surprising for anybody having a good physical knowledge or even possessing complete knowledge of the prior art! The Koppel patent claims that it is valuable (for many reasons as explained in the patent) to perform an orbit transfer where first apogee is increasing and then the same apogee is decreasing!

This is like making a travel for nothing, see Figure 3.

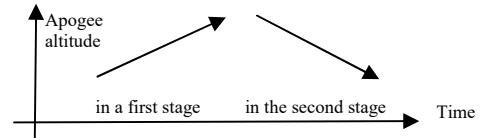

Figure 3: apogee go up and go back for Koppel patent

Indeed some colleagues make such disappointing comments on the new discovered strategy. It was hard to tell them that such strategy with continuous thrust was the best one for going faster (along with many other reasons), and most of the time they couldn't believe that!

There are almost no examples in flight dynamic where such strategy can be valuable.

Only one indirect similar approach is in the Ary Sternfeld bi-elliptic transfer⁸⁾ with impulsive thrusts between circular orbits which is better than the classic Hohmann orbit transfer for large ratio of final to initial radius (or with rather large inclination changes): the use of an intermediate orbit having higher apogee make something similar to the sketch shown in Figure 3.

The orientation of the thrust in Koppel patent is further also claimed in claim 4 and in claim 5

... said first means ...for aligning total thrust in a local horizontal plane, mainly directed in the direction of the speed of the space vehicle

... said second means ...around apogee to bring the total thrust into alignment in a local horizontal plane mainly with the speed direction .. around perigee to bring the total thrust into alignment with a direction opposite to the orbital speed of the space vehicle ...

Those thrust orientation are very useful as analytic rule and for checks of optimised thrust orientations.

2.3 Koppel / Spitzer patent comparison

A comparison between Spitzer and Koppel patents shows that the two patents even if dealing explicitly both with orbit transfer strategies and using Electric Propulsion are quite different.

The major difference come from the fact that Spitzer claims to fire the thrusters (in a first phase) only around the apogee: those are just pulses of thrust and the apogee altitude does not change, while Koppel, on contrary, claims (also in a first phase) to thrust continuously (ignoring possible service interruptions) and increase the apogee altitude with benefits.

Optimisations of the transfer duration for continuous strategies with electric propulsion shows that Koppel main claim must be fulfilled for getting optimal orbit transfer.

While Spitzer say in his patent that it is optimised

with respect to the transfer duration (even the patent title mention the term "Optimal") which is not true when using only electric propulsion because the use of pulses at apogee make the duration of the transfer obviously larger than with a continuous thrust with electric propulsion! However in his second continuation patent *US 5716029*⁶⁾ where electric propulsion is explicitly mentioned in the claims for the first phase, the title does not mention the term optimal anymore...

Spitzer claims and strategy are far from optimum when using electric propulsion, and unfortunately for him, he did not imagine that in the first part of his strategy a continuous thrust with EP could be valuable also for making a completely general strategy for opening efficiently the way for Electric propulsion orbit transfers.

Unfortunately for Spitzer, he did not claim or found the right strategy of full continuous thrust to make shorter the orbit transfer as far as possible.

Thus the two strategies are obviously different.

3. Patentability of such Orbit transfer patent

3.1 Regarding Koppel patent

Discussion with distinguished colleague in flight dynamics in previous conference let him affirms that the Koppel patented strategy was not patentable because now days, using a computer one found obviously and immediately what is claimed, and fully optimised in addition. That discussion showed first that what is claimed (in 1996) is not so bad, and second as one can say :

"the essence of all good patents is to find that they are obvious after having found them"

so, the fact that some people found it obvious suggests that it is one of the good patents perhaps!...

The distinguished colleague in flight dynamics was just forgetting that before having the right computer program, people had to write the optimisation procedure and what is obvious is that such computer program was not born before the disclosure of the patent.

The first known optimisation tool was made by Sophie Geffroy in her thesis of 1997⁹⁾

Also to be mentioned that the optimisation process is not part of any invention because that task is not unobvious task (to be patented, the thing must be considered as unobvious --in addition to novelty and usefulness--).

Even strictly speaking; optimisation cannot be used for making an "improvement patent".

3.2 Recall a patent story

A famous event occurred in 2008 after the launcher 4th stage failure of the satellite AMC-14. Things about its recovery are reported in the web: "*a plan to salvage AMC-14 was abandoned a week ago when SES gave up in the face of patent issues relating to the lunar flyby process used to bring wayward GEO birds back to GEO Earth orbit.*"¹²⁾ The patent in question was a Boeing patent¹⁴⁾. It was reported that

"because SES is currently suing Boeing for an unrelated New Skies matter in the order of \$50 million dollars - and Boeing told SES that the patent was only available if SES Americom dropped the lawsuit."¹²⁾

True or not, this short story shows that patents on orbit transfers can be seriously taken into account moreover when speaking of millions of dollars.

The other side of that story disclosed here is that SES was not aware that other patent with earlier priority date than the Boeing one was already dealing with a possible recovery like the one made for the satellite ASIAT 3¹⁵⁾ for which Boeing made his patent! That was the Koppel-Valentian patent¹⁰⁾. And because the owner of that patent did not pay the annuity in 2007, the use of the Koppel-Valentian patent would have been free of charge for SES in 2008!

As a lesson learned for SES, one can say "never believe someone claiming he has a patent, look first in the database to see if he is not lying!"

3.3 It's obviously invalid to patent orbital trajectories

The previous story raises people to speak freely on such patents. One can read that some people disagree with Orbit transfer patents "*It's obviously invalid to patent orbital trajectories.*"¹³⁾ However, the same post provides also a clear statement "*The patent is not on the existence of a particular trajectory, nor on a basic law of physics. It's a patent on a process to move a spacecraft from one orbit to another by firing rockets at precise times.*"¹³⁾ And the post continues with the analogy:

"*I can't think of a reason why this would be more invalid than a 'composition of matter' patent that is just a list of particular alloys of steel with special properties: after all, it's a law of physics that 18-8 steel has special properties, which was patented.*"¹³⁾

This interesting discussion shows that of course there can be several misunderstanding when speaking of orbital transfer patents or orbital trajectories patents. It is clear that as suggest the title of this paragraph that nobody make a patent only for an orbital trajectory!

Instead what is patented is much more complex on the trajectory evolutions along with several unobvious actions for getting such specific orbital evolution like providing the thrust in the right direction at the right locations. Those actions are needed in order to get the expected benefits.









Combination of both orbit evolution and actions can make the process or the device using it patentable.

4. Other patents on Orbit transfer

To find patents in the database requires some key words in order to make relevant searches.

4.1 Searches on Patent classes

In order to be clear, the classes for inventions dealing with orbit transfers involve mainly the 5/4 following classes:

-  B64G1/00 for Cosmonautic vehicles OR else B64G 1/10 for Artificial satellites; Systems of such satellites; Interplanetary vehicles
 -  B64G1/24 for Guiding or controlling apparatus, e.g. for attitude control (jet-propulsion plants; navigation or navigational instruments; automatic pilots)
 -  B64G1/26 using jets
 -  B64G1/40 for Arrangements or adaptations of propulsion systems
- and sometimes other classes are involved :
-  G05D1/08 for Control of attitude, i.e. control of roll, pitch, or yaw
 -  B64G1/22 Parts of, or equipment specially adapted for fitting in or to, cosmonautic vehicles
 -  B64G1/36 using sensors, e.g. sun-sensors, horizon sensors
 -  B64G1/44 using radiation, e.g. deployable solar
- etc.









But for some patents really dealing with orbit transfer or using new orbit transfer strategies, there are sometime only one class.

Note: Classes may be exclusive, hence a Boolean "OR" shall be used to cover any of the cases "Cosmonautic vehicles" or "Artificial satellites" (B64G1/00 OR B64G 1/10)

Hence, it is generally not enough to search within the classes (B64G1/00 OR B64G1/10) B64G1/24 B64G1/26 B64G1/40. However that is a good starting point for further searches.

For example, with this method, one can found in the US patent database about 30 patents starting from 1970, but only 8 relevant for orbit transfers starting with the Spitzer patent⁶⁾, the last one being from 2015, see **Table 1** based on classes.

Table 1. Orbit transfer patent search based on classes¹⁶⁾.

USpatent	Title	
5595360 ⁶⁾	Optimal transfer orbit trajectory using electric propulsion An apparatus and method for translating a spacecraft (10) from an injection orbit (16) about a central body (10) to geosynchronous orbit (18) in a time efficient manner. The spacecraft (10),...	
5716029 ⁶⁾	Constant sun angle transfer orbit sequence and method using electric propulsion An apparatus and method for translating a spacecraft (102, 108) from an injection orbit (114) about a central body (100) to synchronous orbit (122) in a time efficient manner. The spacecraft (102),...	
6116543 ⁷⁾	Method and a system for putting a space vehicle into orbit, using thrusters of high specific impulse The method serves to place a space vehicle, such as a satellite, on a target orbit such as the orbit adapted to normal operation of the space vehicle and starting from an elliptical initial orbit...	
6186446 see §4.3	Solar array control for electric propulsion system In an electric propulsion system used for transferring a satellite to its operational orbit, a solar array adjustment system is controlled to compensate on a continuous basis for the attitude...	
6213432 ⁷⁾	Method and a system for putting a space vehicle into orbit, using thrusters of high specific impulse The method serves to place a space vehicle, such as a satellite, on a target orbit such as the orbit adapted to normal operation of the space vehicle and starting from an elliptical initial orbit...	
6237876 see §4.3	Methods for using satellite state vector prediction to provide three-axis satellite attitude control Satellite attitude control methods for use during orbit raising operations to follow a predefined thrust trajectory that meets geometric constraints imposed by sensor and/or telemetry and control...	
7113851 see §4.3	Practical orbit raising system and method for geosynchronous satellites A practical orbit raising method and system wherein a satellite quickly escapes the Van Allen radiation belts and payload mass and mission life are maximized. A satellite is launched that contains...	
9180984 no claim relevant to orbit transfer	Methods and apparatus for performing propulsion operations using electric propulsion systems Methods and apparatus to methods and apparatus for performing propulsion operations using electric propulsion system are disclosed. An example apparatus includes a frame, a power source coupled to...	

4.2 Other Searches on References in Patent database

Taking into account all the patents referenced to the 3 first priority date patents found in **Table 1.**, and excluding the words that should not be used for orbit transfer strategies under consideration (*NOT elevator NOT debris NOT shuttle NOT flyby NOT gun NOT cryogenic*) one found an impressive list of 180 patents. But a smaller number of 110 have been granted after the Spitzer patent⁶⁾, see **Table 2** based on references.

That table still includes several patents not dealing with orbit transfer, but it should be rather good bases for experts willing investigate the patented state of art.

Table 2. Orbit transfer patent search based on references¹⁷⁾.

US patent	Title
5595360 ⁶⁾	Optimal transfer orbit trajectory using electric propulsion
5597142	Spacecraft acquisition of orientation by scan of earth sensor field of view
5608634	Low noise spacecraft body rate sensing arrangement for attitude control
5610820	Minimum propellant, zero momentum spacecraft attitude control system
5626310	Space launch vehicles configured as gliders and towed to launch altitude by conventional aircraft
5646847	Universal thruster selection logic for spacecraft attitude control
5669586	Satellite gravity gradient compensation using on-orbit solar array reorientation
5681011	Method for injecting payloads into orbit
5687933	Attitude control for spacecraft with movable appendages such as solar panels
5692707	Universal spacecraft attitude steering control system
5716029 ⁶⁾	Constant sun angle transfer orbit sequence and method using electric propulsion
5738309	Single axis correction for orbit inclination
5749545	Autonomous on-board satellite control system
5765780	Systematic vectored thrust calibration method for satellite momentum control
5788189	Spacecraft and an attitude control method for a spacecraft
5791598	Dynamic bias for orbital yaw steering
5806801	Method and system for formationkeeping between orbiting spacecraft by varying their ballistic coefficients
5806804	Adaptive harmonic disturbance compensation system
5810295	Method and apparatus for a satellite station keeping
5810297	Satellite cluster attitude/orbit determination and control system and method
5813633	Method and apparatus for stationkeeping a satellite offset by pitch rotation
5813634	Method for replacing falling satellites in a satellite communication system
5816539	Orbital assist module and interstage
5845880	Hall effect plasma thruster
5850989	Method and system for rapidly assembling a launch vehicle
5850992	Method for controlling the pitch attitude of a satellite by means of solar radiation pressure
5931421	Arrangement for attitude control and stabilization of a three axes stabilized spacecraft
5934619	Satellite positioning apparatus and process
5957410	Earth oriented satellite and process for controlling the position, nutation and spin
5961076	Modular spacecraft development process
5961077	Method and a system for launching satellites simultaneously on non-coplanar orbits by using highly eccentric orbits and atmospheric braking
5984236	Momentum unloading using gimbaled thrusters
5984237	Delta-V targeting system for three-axis controlled spacecraft
5996941	Method for controlling the attitude of a three-axis stabilized, earth oriented bias momentum spacecraft
6012000	Simplified onboard attitude control based on star sensing
6015116	Fuel efficient methods for satellite stationkeeping and momentum dumping
6020956	Pseudo gyro
6027076	Method for powering a spacecraft with extended-life battery operation
6039290	Robust singularity avoidance in satellite attitude control
6042058	Stationkeeping and momentum-dumping thruster systems and methods
6047927	Escaping singularities in a satellite attitude control
6059233 ¹⁰⁾	Method and a system for launching satellites on non-coplanar orbits, making the use of gravitational assistance from the moon
6067672	Shower curtain closure assembly
6076774	Fuel and thermal optimal spiral earth acquisition
6089507	Autonomous orbit control with position and velocity feedback using modern control theory
6108594	Autonomous attitude acquisition for a stellar inertial attitude determination system
6113035	Attitude control by modulating the rate of propellant depletion
6116543 ⁷⁾	Method and a system for putting a space vehicle into orbit, using thrusters of high specific impulse
6135394	Practical method and apparatus for satellite stationkeeping
6145790	Attitude determination system and method
6186446 see §4.3	Solar array control for electric propulsion system
6213432 ⁷⁾	Method and a system for putting a space vehicle into orbit, using thrusters of high specific impulse
6233507	Eccentric conformance, satellite-position determination module

6237876	see §4.3	Methods for using satellite state vector prediction to provide three-axis satellite attitude control
6253125		Method and apparatus for generating orbital data
6260805		Method of controlling attitude of a momentum biased spacecraft during long-duration thruster firings
6264145		Geostationary earth observation satellite incorporating multiple thruster liquid propellant apogee maneuver system
6282467		Three-axis inertial attitude determination for spinning spacecraft
6285927		Spacecraft attitude determination system and method
6285928		Onboard attitude control using reaction wheels
6292722		Magnetic torquer control with thruster augmentation
6293501		Spacecraft momentum management system
6296207		Combined stationkeeping and momentum management
6305646		Eccentricity control strategy for inclined geosynchronous orbits
6314344		Automated orbit compensation system and method
6315248		Method for satellite injection using a solid fuel rocket motor
6318676		Equatorial-normal body-stabilized spacecraft and control method for inclined orbit operation
6336062		Attitude angle sensor correcting apparatus for an artificial satellite
6341749		Method of simultaneously reducing inclination and eccentricity for geostationary orbit transfer
6356815		Stellar attitude-control systems and methods with weighted measurement-noise covariance matrices
6419104		Compressible plug with internal compression anchor
6435457		Thruster systems for spacecraft station changing, station keeping and momentum dumping
6441776		Method and apparatus for spacecraft payload pointing registration
6470243		Correction of spacecraft steering control law for unexpected orbital inclination effects
6481672		Gimballed thruster control system
6488237		Propellant cross-feed system and method
6502790		Inclined non-uniform planar spaced constellation of satellites
6508438	see §4.3	Spacecraft orbit control using orbit position feedback
6543723	see §4.3	Electric orbit raising with variable thrust
6581880		Energy managed electric propulsion methods and systems for stationkeeping satellites
6588708		Spacecraft methods and structures for acquiring and determining power-safe attitudes
6622969		Maneuver device for artificial satellite
6637701		Gimballed ion thruster arrangement for high efficiency stationkeeping
6672542		Method and system for controlling the eccentricity of a near-circular orbit
6695263		System for geosynchronous spacecraft rapid earth reacquisition
6732977		System for on-orbit correction of spacecraft payload pointing errors
6845950	see §4.3	System for high efficiency spacecraft orbit transfer
6937968		Method and apparatus for sequentially profiling and solving problems in space mission analysis
7059571		Deployable spacecraft mount for electric propulsion
7113851	see §4.3	Practical orbit raising system and method for geosynchronous satellites
7124001		Relative attitude estimator for multi-payload attitude determination
7221264		Method for adjusting interior illumination
7246775	see §4.3	System and method of substantially autonomous geosynchronous time-optimal orbit transfer
7832687		On-orbit storage, plane change, and injection to final orbit of space vehicles
7835826		Attitude determination system for yaw-steering spacecraft
7918420		System and methods for simultaneous momentum dumping and orbit control
8056863		Unified attitude control for spacecraft transfer orbit operations
8096511		System for controlling the deployment of spacecraft required to fly in formation, by simultaneous and high-precision determination of their positions
8282043		Simultaneous momentum dumping and orbit control
8315749		Innovative optimal spacecraft safing methodology
8346410		Method for improving maneuverability and controllability by simultaneously applying both reaction wheel-based attitude controller and thruster-based attitude controller
8457810	see §4.3	Compound steering law for efficient low thrust transfer orbit trajectory
8583297		Method and device for optimization of the mass of a satellite
8676407		Energy-angular momentum diagnostic method for launch vehicle performance
8763957		Spacecraft transfer orbit techniques
8930048	see §4.3	Enhanced compound steering law for general low thrust mission
9108748		Satellite orbit raising using electric propulsion
9108749		Spacecraft momentum management
9284068		Fast-low energy transfer to Earth-Moon Lagrange point L2
9399528		Method and system for stationing a satellite

4.3 Improvement patents

The patent lists shows that without saying anything on the patented orbit transfers, many patents can be considered in some ways as "improvement patent" of the Spitzer or Koppel patents:

- for example the Boeing US8457810, Jun.4,2013, "compound steering law for efficient low thrust transfer orbit trajectory" as well as US 8930048 Jan. 6, 2015, assume only a "processor" for computing a

orbit transfer and because nothing in the claims forbid such processor to not follow explicitly the Koppel claims, it follows that such patent can include the Koppel patents, hence in this case (*the patent authors do not mention or check anything about the evolution of apogee and perigee altitude during the orbit transfer but because it is said to be very efficient, it necessarily follows Koppel claim*), this is called an improvement patent, which means that it is useless without the primary patent(s) license(s).

The same occurs with other Boeing US6508438 B2, Jan.21,2003 where the term "trajectory provider" is used in the claims with a "trajectory calculator".

The same occurs in Lockheed-Martin US 7246775 B1 Jul. 24, 2007 where the term "thrust trajectory generation logic" is used in the claims.

The same occurs in Lockheed-Martin US 6845950 B1 Jan.25,2005 where the term "computing" is used in the claims "...computing a continuous-firing thrust trajectory to achieve an orbit transfer; computing an intermittent-firing thrust trajectory to achieve the orbit transfer" and also using the term "threshold value" for the intermittent-firing that is not explicitly forbidden to be equal 0 and thus this possibility enables continuous thrust as claimed in Koppel patent for getting its benefits for minimizing the number of commutations (which are switch on and switch off of the propulsion). Switch on processes and sequencing are always a bit critical and risky with several thrusters each one not aligned toward the centre of mass even if the total resultant is aligned.

Also in the US 6186446 issued Feb. 13, 2001 from Space System/Loral Inc., the claim mentions an "onboard attitude control processing ... optimized thruster attitude...through a series of transition orbits" where said "processing" does not forbid to follow claims from Koppel patent.

In the US 6237876 issued May 29, 2001 from Space System/Loral Inc., it is claimed a "generating predefined thrust trajectory or thrust vector profile that is designed to raise a satellite from a transfer orbit to GEO" where said "thrust vector profile" does not forbid to follow claims from Koppel patent.

In the US 9108748 issued Aug. 18, 2015 from Space System/Loral LLC, it is hard to find something unobvious because as said by the authors it "address practical details" that are of course known for those skilled in the art... It claims a "profile generator ... computes an ideal electric orbit raising profile". and in the same claim process "onboard ...orbit raising profile including ... ignition phase, a burn phase, and a shutdown phase that are autonomously repeated..." where the repetition rate as said in the text may last many orbital revolutions (a figure of "n" times is cited without any bounds): that enable clearly to make continuous thrust ignoring possible

service interruptions as claimed in Koppel patent which is incompletely and wrongly cited in that Space System/Loral patent.

🌱 The US 6543723 issued April 8, 2003 from Space System/Loral Inc., can be considered as an improvement patent of the Spitzer patent because it rely on chemical and electric propulsion and nothing forbid the fact that the so-called "*intermediate orbit*" has a semi-major axis equal to the one of GEO as in Spitzer patent.

🌱 The US 7113851 issued Sep. 6, 2006 from Gelon et al. is quite similar to Spitzer patent but in the claims it is prohibiting specifically that "*the semi-major axis of the intermediate orbits*" to be equal to the one of the final orbit as claimed by Spitzer.

However, this patent that claim "*a processor ... thruster firing profile*" can be considered as clearly an improvement patent of Koppel patent because nothing prohibits to follow the Koppel claims once the so called intermediate orbit is reached. On that point those authors seem to have rediscovered the Koppel patent that was not cited in the prior art.

While using terms hiding patented purposes, some possible improvement patents of Spitzer or Koppel patents can be not seen by the examiner as such, even the examiner may not cite at all the primary patent in the prior art. Hence the owner of the patent (or a licensee who pay for it) may even not know that at the time of the implementation, he can make some possible infringements with respect to other patents (and a need to buy also licence --if possible-- for the primary patent).

Most of the time, in the improvement patents it is really hard to find anything "unobvious" as required for being patented, except a hidden use of any primary patent.

Moreover, most of the time, such improvement patents using terms like "*steering law, trajectory provider, calculator, computing, processing, profile, ...*" the disclosure is not complete because nobody can implement such patent without the knowledge of what is inside such law or computer software!

Such laws or software are kept secret within the claims of the patent. Hence the real patentability of the improvement patents as exhibited above in this paragraph is in question because such patents "as-is" are not useful.

4.4 Review of Orbital transfer patents

The review of the patents list has been undertaken carefully. Among all the patents exhibited in the lists above, only two are describing without any secret the evolution of the orbital path and the actions to be taken in order to perform the orbit transfer: those are only the Spitzer patent⁹ and much more generally the Koppel patent⁷.

As seen above §4.3 all other patents claiming orbit transfer are on the specific orbit transfer itself keeping the secrecy on the how to perform the orbit transfer itself.

Eventually for experts in fight dynamics only the

Spitzer patent and much more generally the Koppel patent should be taken into account before releasing any analysis on orbit transfer for highlighting the use or not of patented strategies.

5. Conclusions

The paper has pointed out that patents on orbit transfer should be seriously taken into account for at least mentioning that analysed cases on orbit transfer may infringe or not patents.

The two first patents using electric propulsion for orbit transfer have been described in detail: for experts in fight dynamics only the Spitzer patent and much more generally the Koppel patent should be considered regarding the orbit transfer itself.

Some recommendations have been provided. Those are summarised as:

- 🌱 Patents dealing with new flight dynamics orbit transfers (and granted in the state of registration of the S/C) are in force and their infringement or counterfeits can be brought to justice in the state of registration of the S/C.
- 🌱 The essence of all good patents is to find that they are obvious after having found them, so be prudent with obvious strategies!
- 🌱 Optimisation process is not part of any invention because that task is not unobvious task.
- 🌱 To be patented, the thing must be considered as unobvious (along with novelty and usefulness).
- 🌱 Never believe someone claiming he has a patent, look first in the database to see if he is not lying!
- 🌱 Always consider patents in the view of possible so called type of "improvement patent".
- 🌱 Improvement patents are useless without their primary patent license.
- 🌱 The real patentability of the improvement patents relying on secret law or computer software making incomplete disclosure and non-usefulness is in question.

6. Acknowledgements

Author would like to thank Mr. Steven Wood³⁾ from The Research Foundation for The State University of New York for his help in the review of the paper.

7. References

- 1) *Registration Convention*: Convention on the Registration of Objects Launched into Outer Space, entered into force 15 Sept. 1976, 28 U.S.T .695, 1023 U.N.T.S. 15, Art.II(1).
- 2) *Outer Space Treaty*: Treaty on Principles Governing the Activities of States in the Exploration and Use of Outer Space, Including the Moon and Other Celestial Bodies, entered into force Oct.10,1967, 18 U.S.T. 2410, 610 U.N.T.S. 205, Art. VIII. <http://www.unoosa.org/oosa/en/ourwork/spacelaw/treaties/introouterspace treaty.html>
- 3) Steven Wood, Encouraging the Innovation and Technological Advancement Requisite for Greater in-Depth Exploration of Outer Space Through Patents, IAC-14,E7,2,x23044, *65th International Astronautical Congress*, 29 September 2014, Toronto, Canada.
- 4) M.J. Kleiman, Patent Rights and Flags of Convenience in Outer Space, Patents in Space, *The Space Review*, (07/02/2011), available at <http://www.thespacereview.com/article/1772/1>, last accessed on 13/03/2017.
- 5) Theodore N. Edelbaum. Propulsion Requirements for Controllable Satellites, *ARS Journal*, Vol. 31, No. 8 (1961), pp. 1079-1089.
- 6) Arnon Spitzer, Optimal transfer orbit trajectory using electric propulsion, *patent US 5595360 244/158.5, 1997-01-21 (priority 1994-03-25)*.
Also see *US 5716029*
- 7) Christophe Koppel, Method and a system for putting a space vehicle into orbit, using thrusters of high specific impulse, *patent US 6213432, 2001-04-10 (priority 1996-04-05)*.
Also see *US 6116543*
- 8) Ary Sternfeld, Sur les trajectoires permettant d'approcher d'un corps attractif central à partir d'une orbite képlérienne donnée, *Comptes rendus de l'Académie des sciences, Paris, Tome 198 P. 711-713. 1934-02-12*
- 9) Sophie Geffroy, Généralisation des techniques de moyennation en contrôle optimal. Application aux problèmes de transfert et rendez-vous orbitaux à faible poussée, *Thèse de doctorat n° 1352/1997*, date 30 October 1997.
- 10) Christophe Koppel, Dominique Valentian, A Method and a system for launching satellites on non-coplanar orbits, making the use of gravitational assistance from the moon, *patent US 6059233 2000-05-09 (priority 1996-12-31)*
- 11) Arnold B. Silverman, The Relationship Between Basic and Improvement Patents, available at <http://tms.org/pubs/journals/JOM/matters/matters-9501.html> last accessed on 13/03/2017.
- 12) Staff Writers, Boeing Patent Shuts Down AMC-14 Lunar Flyby Salvage Attempt available at http://www.space-travel.com/reports/Boeing_Patent_Shuts_Down_AMC_14_Lunar_Flyby_Salvage_Attempt_999.html last accessed on 13/03/2017.
- 13) Satellite killed by trajectory patent available at <https://news.ycombinator.com/item?id=3999756> last accessed on 13/03/2017.
- 14) Jeremiah O. Salvatore, Cesar A. Ocampo, Free return lunar flyby transfer method for geosynchronous satellites *patent US 6116545 2000-09-12 (priority 1998-04-09)*
- 15) Andrew Pollack, Trying to Save Satellite, Company Is Sending It to Moon , *The New York Times APRIL 30, 1998*
- 16) Patents databases, for example <http://www.freepatentsonline.com/>
- 17) Patents databases, for example <http://www.freepatentsonline.com/> with search line: (CN102424116A OR CN105607478A OR EP2977321A1 OR US20040056146 OR US20040176883 OR US20050109878 OR US20120097796 OR US20120097797 OR US20140061386 OR US20140077036 OR US20140166814 OR US20150284111 OR US20150307214 OR US5961077 OR US6097997 OR US6102337 OR US6116543 OR US6182928 OR US6186446 OR US6213432 OR US6237876 OR US6253124 OR US6278946 OR US6341250 OR US6341749 OR US6364252 OR US6385512 OR US6435457 OR US6442482 OR US6464174 OR US6508438 OR US6543723 OR US6577930 OR US6581880 OR US6637701 OR US6672542 OR US6695263 OR US6702234 OR US6732977 OR US6739555 OR US6751531 OR US6999860 OR US7051980 OR US7113851 OR US7832687 OR US7835826 OR US7988097 OR US8113468 OR US8457810 OR US8457810 OR US8583297 OR US8763957 OR US8768622 OR US8930048 OR US8930048 OR US9108748 OR US9108748 OR US9108749 OR US9108749 OR US9180984 OR US9284068 OR US9399528 OR WO1998042570A2 OR WO1998042570A3 OR WO2003084813A2 OR WO2003084813A3 OR WO2005044664A3) NOT elevator NOT debris NOT shuttle NOT flyby NOT gun NOT cryogenic